

TufLok®

BN 5210 - Hex socket set screws with flat point and TufLok® patch

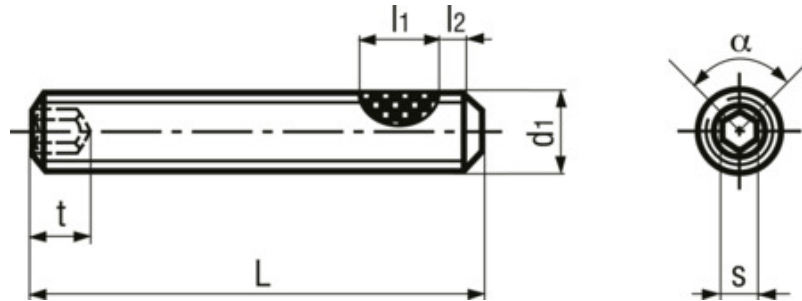

Standard **ISO 4026**, DIN 913, ~UNI 5923, ~ČSN 021187

Manufacturer

TufLok®

Additional information

Coating angle α in the screw body area approx. 90°. Edge zone (spray transition) up to 180°.
Coating length $l_1 = \sim 4$ to 6 thread turns.
Around 1 to 2 thread turns remain uncoated to ensure flawless installation (l_2).

Drive

Hexagon socket

Brand

TufLok®

Material

Steel

Surface

zinc plated blue

Hardness

45 H

Warnings

ISO 4042

Quenched and tempered fasteners ≥ 360 HV and tempered case-hardened fasteners with electroplated coatings:
Susceptible to hydrogen embrittlement!
Further notes on residual risks can be found on our web page: Notes on use

Set screws are not intended to be tensile-loaded.

Article no.	d1	L	s	t min.
1380052	M3	6	1,5	2
1380060	M3	8	1,5	2
1380079	M3	10	1,5	2
1380087	M3	12	1,5	2
3136526	M4	5	2	2,5
1380095	M4	6	2	2,5
1380109	M4	8	2	2,5
1380117	M4	10	2	2,5

Article no.	d1	L	s	t min.
1380125	M4	12	2	2,5
1380133	M4	16	2	2,5
1576305	M5	6	2,5	3
1380141	M5	8	2,5	3
1380168	M5	10	2,5	3
1380176	M5	12	2,5	3
1380184	M5	16	2,5	3
1380192	M5	20	2,5	3
1576313	M6	6	3	2
1380206	M6	8	3	3,5
1380214	M6	10	3	3,5
1370545	M6	12	3	3,5
1370553	M6	16	3	3,5
1370561	M6	20	3	3,5